

SLOT DIFFUSERS – SUPPLY DIFFUSERS-CKD-03

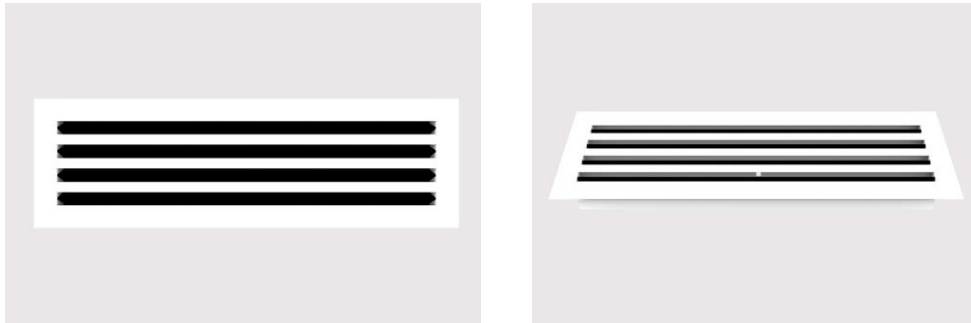

SLOT DIFFUSERS- CKD-03

AREA OF USAGE AND FEATURES:It is used as blowing and suction diffusers in Hvac systems. It is suitable for horizontal and vertical shots. The ideal shooting distance is between 2.5-8 m. It is used in ceiling and wall applications. It is standard bridge mounted. The way of mounting can be changed optionally.

MATERIAL: Body and wings are made of aluminum profile manufactured by extrusion method.

SURFACE COATING: The product can be manufactured in any color with electrostatic powder paint. The wings are manufactured in standard black color.

ACCESSORIES: Plenum box

AIR SHOT TYPES:

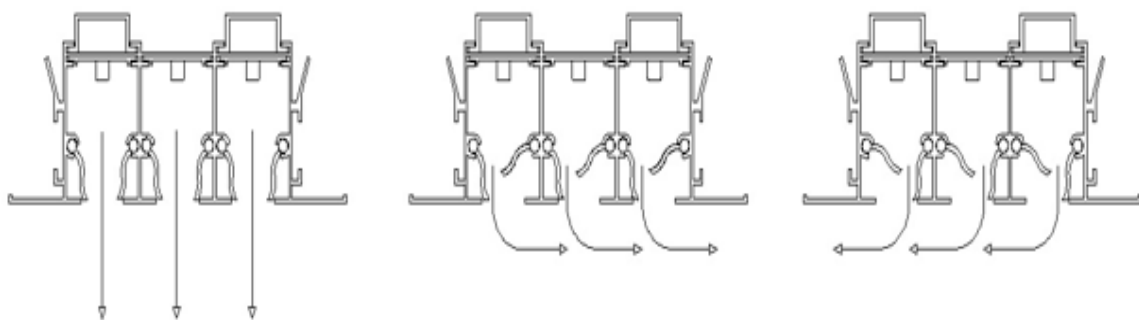

VERTICAL SHOOT

HORIZONTAL SHOOT

TECHNICAL MEASUREMENT :

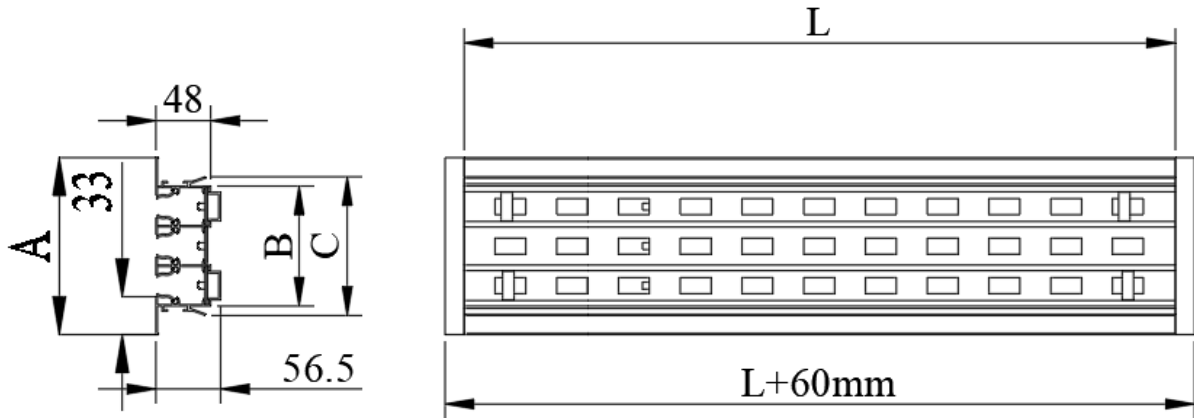

NUMBER OF SLOTS	1	2	3	4	5	6
A (mm)	85	120	156	191	227	259
B (mm)	36	71	106	142	177	210
C (mm)	52	88	123	159	194	227
	500 - 600 - 700 - 800 - 900 - 1000 - 1100 - 1200 - 1300 - 1400 - 1500 - 1600 - 1700 - 1800 - 1900 - 2000					

SLOT MOUNTING DETAIL :

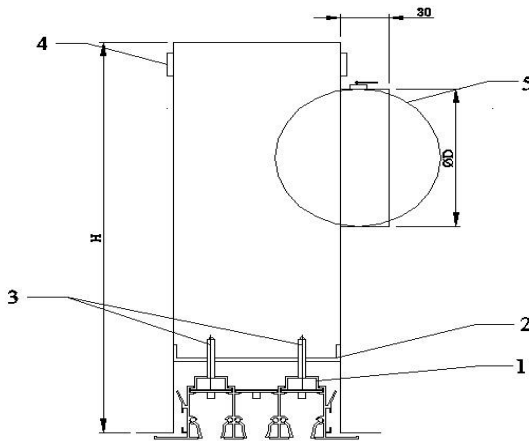

- 1- Slot Bridge Piece (On Slot)
- 2- Box Bridge piece (Inside the box)
- 3- Assembly Screw And Special Nut (M5 * 50)
- 4- Box Hanger Apparatus
- 5- Box Perforated Damper (Internal Control)

L (mm)		NUMBER OF SLOTS					
		1	2	3	4	5	6
500 – 1500	ØD (mm)	138	198	218	248	248	248
	h (mm)	218	278	298	328	328	328
1500 – 2000	ØD (mm)	*138 x 2	*198 x 2	*218 x 2	*248 x 2	*248 x 2	*248 x 2
	h (mm)	273	341	400	487	487	487

PIECE SLOT MOUNTING DETAIL :

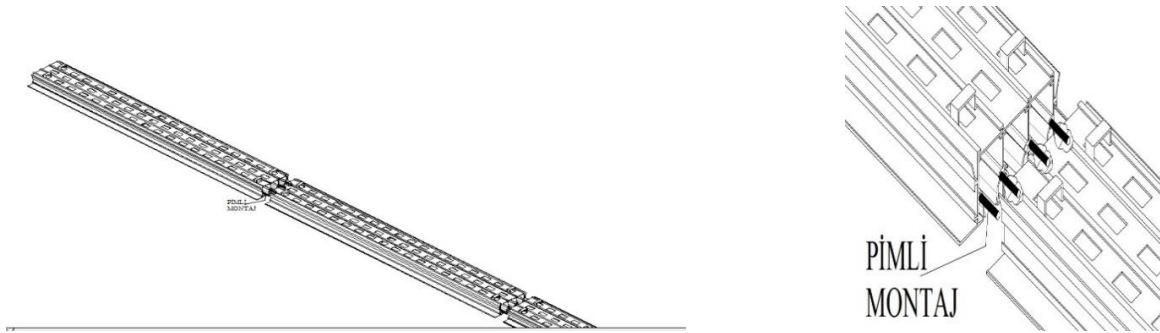

PIN MOUNTING

VERTICAL SHOOT :

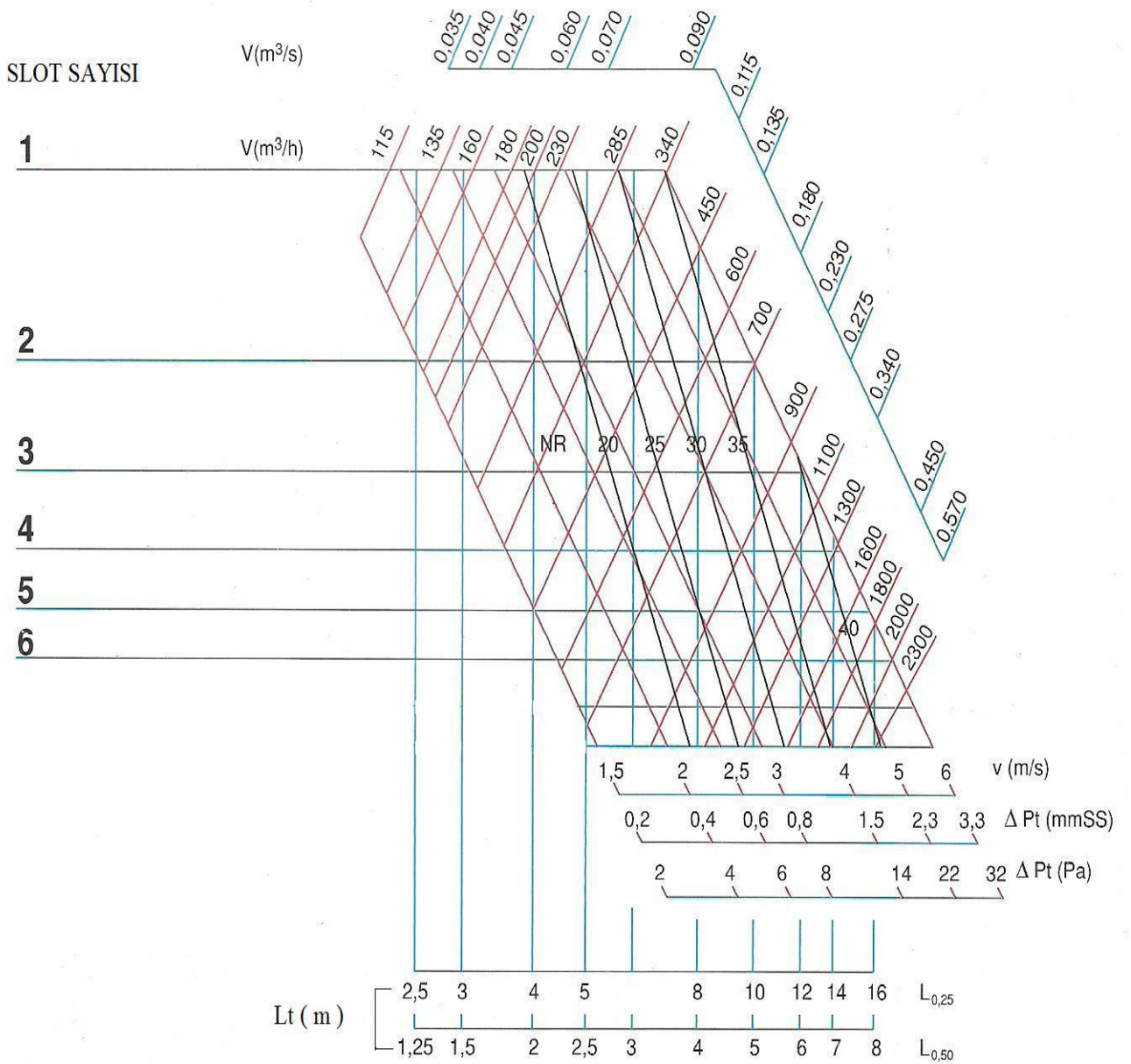

HORIZONTAL SHOOT

SLOT SAYISI

